

SHARK® 50B

DUAL BACNET MS/TP & MODBUS TCP/IP
COMMUNICATING MULTIFUNCTION POWER METER

Use with Both
Building Management
and Dashboards



Shark® 50B
Power Meter/Transducer

Features

- Multifunction Measurements of AC Voltage, Current, Power and Energy
- Industry Recognized Superior 0.5% Energy Class Accuracy
- BACnet MS/TP Serial
- Modbus TCP/IP Ethernet
- Highly Reliable Industrial Rated Design

Applications

- LEED Projects
- Smart Buildings
- Commercial Energy Management
- HVAC Efficiency Monitoring
- Building Management Systems

Introduction

Electro Industries introduces our industry leading revenue grade power meter with native BACnet MS/TP and Modbus TCP/IP protocols. This universal meter is designed to integrate seamlessly into existing and new building management systems. The unit allows users to gather data on voltage, current, power and energy usage throughout a facility.

The Shark® 50B power meter was designed to be the perfect device for “Green” initiatives, LEED certified projects, smart buildings and all kinds of smart energy projects. This multifunction power meter's dual communication

interface provides the information needed by both energy management and building control applications.

Having one metering product to fill almost every metering integration application is essential for a smooth and cost effective energy management system integration. This meter fills that need with highly accurate energy measurements and flexible communication capability.

The unit utilizes advanced DSP technology, high sampling rates and 24 bit analog to digital conversion to measure and analyze power accurately and reliably.

Highly Accurate Energy Measurements Perfect for Building Management Integration



SHARK® 50B POWER METER

Shark® 50B with BACnet: the “Green” Choice

The Shark® 50B meter with BACnet MS/TP supports building energy management strategies, LEED certification and other Green Building initiatives. By letting you track energy use and power with your building management system, the meter gives you the information you need to accurately identify cost saving measures and respond to power problems when

they arise. The Shark® 50B meter’s readings can also be viewed and analyzed using CommunicatorPQA™ software, which lets you program the meter and view real-time readings remotely.

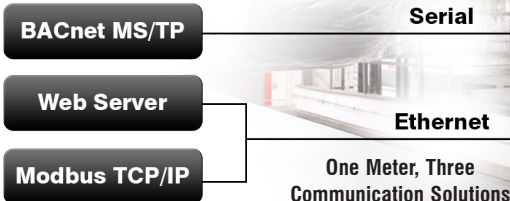

BACnet Objects		
Volts A-N	VARh Net	Positive Watts, 3-Phase, Average Demand
Volts B-N	kVARh Net	Positive kWatts, 3-Phase, Average Demand
Volts C-N	Frequency	Positive VARS, 3-Phase, Average Demand
Volts A-B	Neutral	Positive kVARs, 3-Phase, Average Demand
Volts B-C	Current	Negative Watts, 3-Phase, Average Demand
Volts C-A	Whr Received	Negative kWatts, 3-Phase, Average Demand
Amps A	kWhr Received	Negative VARs, 3-Phase, Average Demand
Amps B	Whr Delivered	Negative kVARs, 3-Phase, Average Demand
Amps C	kWhr Delivered	Positive VARS, 3-Phase, Max Average Demand
Total Watts	Whr Net	Positive kVARs, 3-Phase, Max Average Demand
Total kWatts	kWhr Net	Negative Watts, 3-Phase, Max Average Demand
Total VARs	Total Whr	Negative kWatts, 3-Phase, Max Average Demand
Total kVARs	Total kWhr	Negative VARs, 3-Phase, Max Average Demand
Total VA	Positive VARh	Negative kVARs, 3-Phase, Max Average Demand
Total kVA	Positive kVARh	Positive Watts, 3-Phase, Max Average Demand
Total PF	Negative VARh	Positive kWatts, 3-Phase, Max Average Demand
Total VAh	Negative kVARh	VAs, 3-Phase, Average Demand
Total kVAh		kVAs, 3-Phase, Average Demand
Total VARh		VAs, 3-Phase, Max Average Demand
Total kVARh		

The 56 pre-defined objects in the Shark® 50B meter’s BACnet MS/TP protocol

Measured Parameters	Accuracy % of Reading	Display Range
Voltage L-N	0.2%	0-9999 V or kV
Voltage L-L	0.4%	0-9999 V or kV Scalable
Current	0.2%	0-9999 A or kA
+/- Watts	0.5%	0-9999 Watts, kWatts, MWatts
+/- Wh	0.5%	5 to 8 Digits Programmable
+/- VARs	1.0%	0-9999 VARs, kVARs, MVARs
+/- VARh	1.0%	5 to 8 Digits Programmable
VA	1.0%	0-9999 VA, kVA, MVA
VAh	1.0%	5 to 8 Digits Programmable
PF	1.0%	+/- 0.5 to 1.0
Frequency	+/- 0.01 Hz	45 to 65 Hz
% Load Bar	1-120%	10 Segment Resolution

Note: Typical results are more accurate. Applies to 3 Element WYE and 2 Element Delta Connections. Add 0.1% of Full Scale plus 1 digit to Accuracy specs for 2.5 Element connections.

View Real Time Data and Configure the Meter through the Web Server

The Shark® 50B meter is field configurable and easy to use. Its BACnet structure is configured through the built-in web server. Additionally, the web server can also be used to view real time data.

With the Shark® 50B meter, the user has the benefit of serial MS/TP protocol and a web enabled meter, simultaneously.

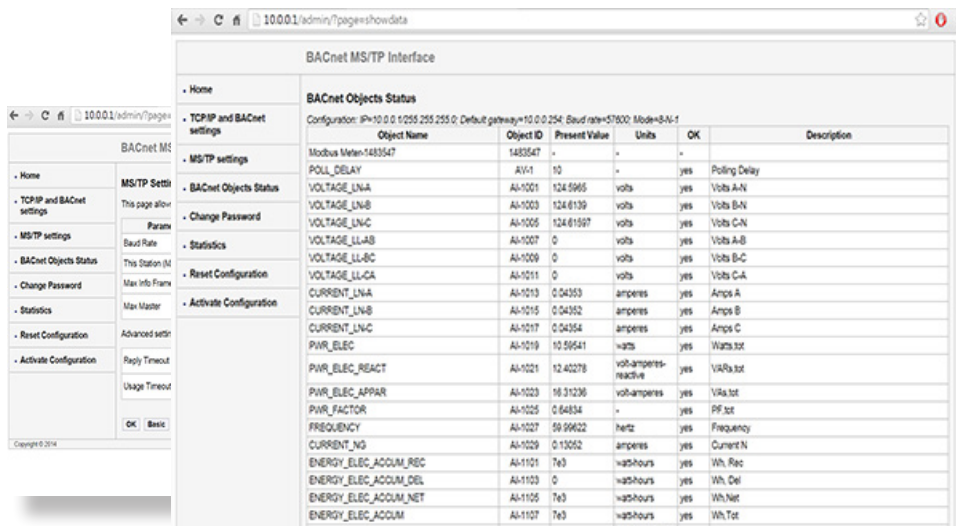

Dimensional Drawings

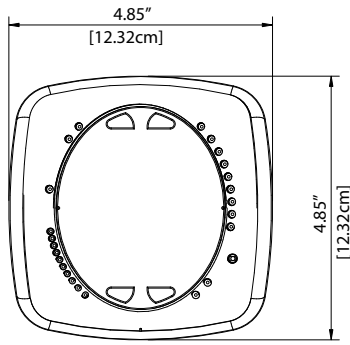

FRONT VIEW

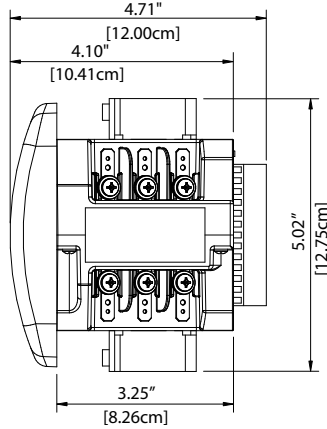

SIDE VIEW

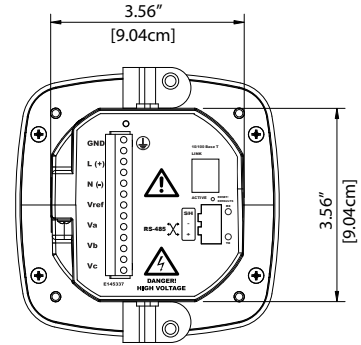

REAR VIEW

Wiring Diagrams

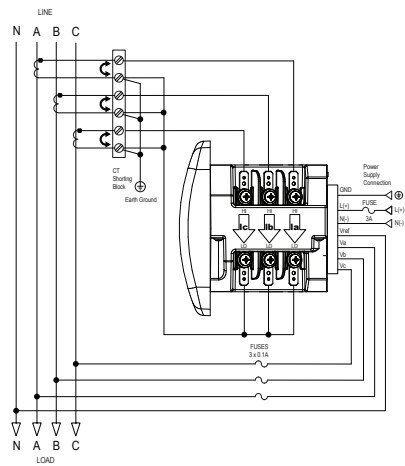

3 Phase, 4 wire WYE Direct

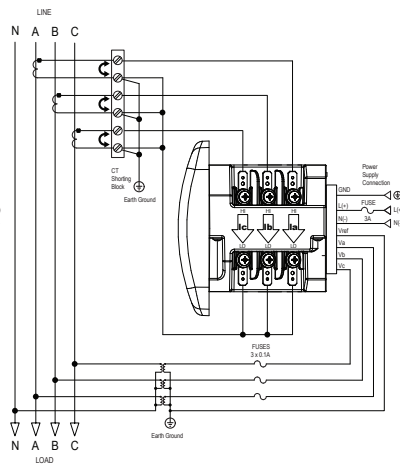

3 Phase, 4 wire WYE with PTs

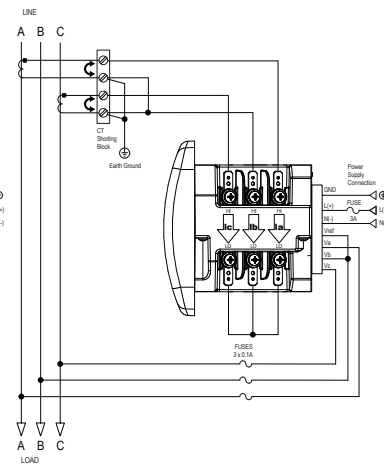

3 Phase, 3 wire Delta Direct

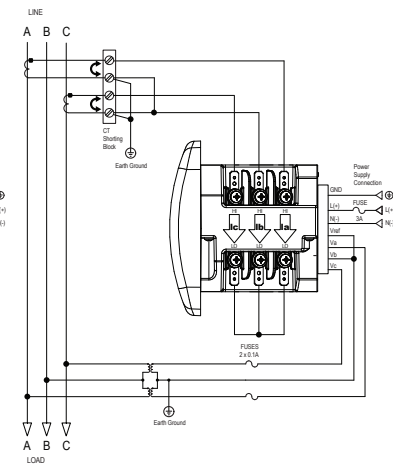

3 Phase, 3 wire Delta with PTs

Shark® 50B Meter ANSI & DIN Mounting

The unit mounts directly in an ANSI C39.1 (4" round form) or an IEC 92 mm DIN square form. This is perfect for new installations and for existing panels. In new installations, simply use DIN or ANSI punches. For existing panels, pull out old analog meters and replace them with the Shark® 50B meter. The meter uses standard voltage and current inputs so that CT and PT wiring does not need to be replaced.

- Perfect for switchgear panel direct retrofit
- Uses minimal panel space
- Mounts in only 4.25" panel depth

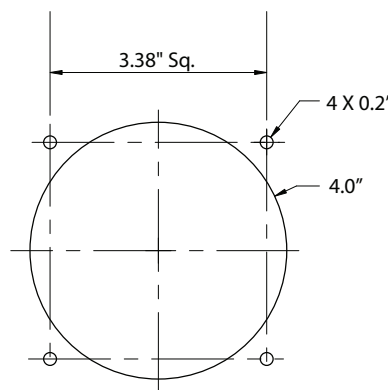

ANSI Mounting

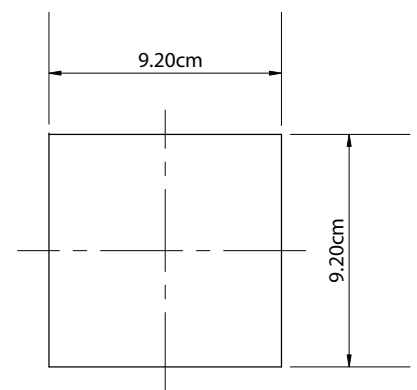

DIN Mounting

Specifications

Voltage Inputs

- Up to 416 V AC L-N and up to 721 V AC L-L
- Universal Voltage Input
- Input Withstand Capability – Meets IEEE C37.90.1 (Surge Withstand Capability)
- Programmable Voltage Range to Any PT Ratio
- Supports: 3 Element WYE, 2.5 Element WYE, 2 Element Delta, 4 Wire Delta Systems
- Burden: 0.0144 VA/Phase at 120 Volts
- Input Wire Gauge Max (AWG 12 / 2.5 mm²)

Current Inputs

- Class 10: (0 to 10) A, 5 A Nominal, 10 A Maximum
- Fault Current Withstand (For 23 °C, 3 Phase Balanced WYE or Delta load): 100 A for 10 Seconds, 300 A for 3 Seconds, 500 A for 1 Second
- Programmable Current to Any CT Ratio

- Burden 0.005 VA Per Phase Max at 11 A
- 0.1% of Nominal
- Pass Through Wire Gauge Dimension: 0.177" / 4.5 mm
- Continuous Current Withstand: 20 A for Screw Terminated or Pass Through Current Connections

Isolation

- All Inputs and Outputs are Galvanically Isolated to 2500 Volts AC

Environmental Rating

- Storage: (-20 to +70) °C
- Operating: (-20 to +70) °C
- Humidity: to 95% RH Non-Condensing
- Faceplate Rating: NEMA12 (Water Resistant) Gasket Included
- Protection: IP30 - Meter Front/Back, Optional DIN Rail Mounting

Sensing Method

- RMS

- Sampling at 400+ Samples per Cycle on All Channels Measured Readings Simultaneously

Update Rate

- All Parameters Every 60 cycles

Power Supply

- (90 to 265) Volts AC
- AC Power Supply Only

Communication Format

- BACnet Serial MS/TP (RS485)
- 10/100 BaseT Ethernet Modbus TCP/IP

Dimensions and Shipping

- Weight: 2 lbs
- Basic Unit: (H4.85 x W4.85 x L4.25) in.
- Mounts in Either 92 mm Square DIN or ANSI C39.1 4" Round Cutouts
- Shipping Container Dimensions: 6" Cube

Meter Accuracy

- See Page 2

Compliance

- IEC 62053-22 (Class 0.5S)
- ANSI C12.20 (0.5 Accuracy Class)
- ANSI (IEEE) C37.90.1 Surge Withstand
- ANSI C62.41 (Burst)
- EN 61000-6-2 - Immunity for Industrial Environments: 2005
- EN 61000-6-4 - Emission Standards for Industrial Environments: 2007
- EN 61326-1 - EMC Requirements: 2006
- Certified to UL 61010-1 and CSA C22.2 No. 61010-1, UL File: E250818
- REACH Compliant
- RoHS Compliant

Ordering Information: To order, please fill out ordering guide:

Option Numbers:	Model	Mounting
Example: Shark 50	-	X
	Shark 50B (meter / transducer)	X ANSI Mounting DIN DIN Mounting Brackets (Euro Mounting)

Ordering Instructions: Email or fax part number above, plus quantity, to the address below. Lead times are typically stock to 2 weeks. Call toll-free 1-877-EIMETER to speak to a sales engineer with any technical questions.

Additional Accessories

Solid Core Current Transformers*

EI-2DARL-101: ANSI Rated 100/5A solid core CT with 1.0" window

EI-2DARL-201: ANSI Rated 200/5A solid core CT with 1.0" window

EI-5ARL-401: ANSI Rated 400/5A solid core CT with 1.5" window

Split Core Current Transformers*

EI-1SP-100-00: 100/5A split core CT with 0.84" x 2.00" window

EI-1SP-200-00: 200/5A split core CT with 0.84" x 2.00" window

EI-WC4-400-RA05: 400/5A split core CT with 1.3" x 1.7" window

Shorting Block and Fuses

EI-SB-6TC: CT Shorting Block for easy install

EI-CP: Voltage and power supply protection fuse kit

Compliance Documents

Certificate of Calibration, Part # CCal – This provides Certificate of Calibration with NIST traceable Test Data.

